

# Latest Advances and Development on Wind-Powered Hydrogen Production

Ashutosh Kapil

Department of Physics, DAV College, Chandigarh

---

## ARTICLE DETAILS

### Article History

Published Online: 10 December 2018

### Keywords

Hydrogen production, wind power generation, non-grid-connected, prospect.

---

## ABSTRACT

The hydrogen production technology by wind power is an effective mean to improve the utilization of wind energy and alleviate the problem of wind power curtailment. To begin with, the essential standards and specialized attributes of the hydrogen production innovation by wind power are momentarily presented. At that point the historical backdrop of the hydrogen production innovation is audited, and on this premise, the hydrogen production framework by wind power is expounded in detail. Moreover, the possibility of the use of the hydrogen production innovation by wind power is examined and talked about. Eventually, the vital innovation of the hydrogen production by wind power and the issues to be addressed are thoroughly investigated. The improvement of hydrogen production innovation by wind power is dissected from numerous viewpoints, which gives reference to future advancement of hydrogen production innovation by wind power.

---

## 1. Introduction

Traditional hydrogen production by electrolysis in the generation of electricity will make a lot of pollutant emissions. Nonetheless, the hydrogen production innovation by wind power is the utilization of "green" force and it is a perfect innovation. As of late, numerous researchers have investigated and checked the economy and practicality of hydrogen production from wind power.

The hydrogen production project by wind power was first proposed by the United States, the venture makes hydrogen by a variety of generators associated with an electrolytic reactor. Europe is the pioneer in the field of putting away energy by changing over wind energy into hydrogen. The EU intends to accomplish reasonable improvement without dependence on petroleum products before the finish of 2060, and the significant piece of accomplishing this objective is to store and apply sustainable power in the method of hydrogen. The EU has executed a showing project on hydrogen production innovation in Greece and Spain, and the venture consolidated wind energy with hydrogen production innovation. It includes hydrogen stockpiling, power modules, and desalination innovation, and it gives "green" hydrogen energy for energy stockpiling, power supply, and supply of new water.

In 2008, the Chinese Urban Planning and Design Institute proposed the development example of the hydrogen production base of seawater desalination. North China Electric Power University, Shanghai University of Finance, and Economics and Beijing Green Source Technology Co., Ltd, etc examined the practicality and economy of wind power age hydrogen production, and the issues looked by hydrogen production by wind power. In 2011, the territory of Brandenburg, Germany, fabricated and worked the world's first wind-hydrogen half and half force station. In 2013, China National Electricity Co., Ltd proposed another method of huge scope wind power stockpiling wind power hydrogen production and energy component power age framework, and brought up that the compelling stockpiling of hydrogen and energy unit innovation are the key specialized issues of the framework. In 2014, Germany proposed utilizing the hydrogen gas created by wind ability to infuse gas net and set up exhibit plan. This is a

significant start of wind power production. The public environmentally friendly power research center in U.S. furthermore, Xcel energy have dispatched a show Wind2H2 project, the venture utilizes wind force and photovoltaic to create and store hydrogen, and it amplifies the utilization of environmentally friendly power and streamlines energy move. In this way, Japan additionally proposed a progression of plans and applications for the hydrogen production of wind power. In September 2016, the 70 MPa hydrogenation station (Tongji-Xinyuan hydrogenation station) in China was finished in Dalian, and the autonomous advancement of key gear was acknowledged in China. In 2017, the principal hydrogen production industry application project in China: the hydrogen production station of Hebei Guyuan hydrogen production project was effectively begun, it is the world's biggest hydrogen production undertaking, and it gives insight and establishment to the acknowledgment of hydrogen production scale and industrialization of wind power. The hydrogen production innovation by wind power has grown quickly, however there is as yet an issue of low hydrogen production proficiency and high energy utilization for hydrogen production.

Dutton et al. (2000) anticipated the viable issues of the hydrogen production framework by wind power and the potential issues of the advancement of the hydrogen production by wind power by summing up the EU-supported hydrogen production projects. The impact of wind power change on the activity of electrolyzer was brought up, and the strategy for improving the yield force of the wind turbine is advanced. Kassem (2003) surveyed the financial aspects and plausibility of hydrogen production innovation by wind power dependent on the irregularity of wind energy. The wind power plant creating hydrogen by electrolysis was recreated by Valdés et al. (2013), and two strategies for upgrading the force of hydrogen production by wind power were advanced and recreated. Belmokhtar et al. (2014) set forward a control procedure dependent on fluffy rationale for ideal administration of hydrogen production innovation by wind power. Sarrias-Mena et al. (2015) examined the coupling activity of the electrolyzer and the wind turbine for the hydrogen production,

and the working qualities of the four diverse electrolyzers were thought about.

As a rule, the hydrogen production innovation by wind power is still at the phase of hypothetical examination. There are still a great deal of issues to be tackled, like profoundly versatile wind turbine, power control and change technique for wide force variance, high force hydrogen production hardware reasonable for wide force vacillation, more proficient energy saving innovation for hydrogen production, coordinated control and security of hydrogen production, etc. More productive and safe hydrogen stockpiling innovation and energy unit additionally assume a pivotal part in the drawn out advancement of hydrogen.

By and large, Europe, addressed by Germany, has grown moderately quick in hydrogen production, and there are exhibition projects in hydrogen production, hydrogen stockpiling, and hydrogen use. As of now, hydrogen is fundamentally utilized in hydrogen fuel age and hydrogen energy unit. The advancement of hydrogen vehicles in new energy vehicles is moderate due to the requirement for immense foundation, (for example, hydrogen station, hydrogen transport organization, and so forth) Hydrogen energy is being given increasingly more consideration as a spotless energy. It

is a significant vital heading for the improvement of environmentally friendly power.

**2. Basic principle of hydrogen production technology by wind power**

The hydrogen production technology by wind power is considered as a "clean and efficient mode of energy use." This mode is utilized to produce hydrogen by electrolysis which can't be consumed by the force network or to create hydrogen straightforwardly by utilizing the power produced by non-lattice associated wind power. Hydrogen is put away and shipped after compression and is applied to hydrogen energy component vehicles, etc. Hydrogen production innovation by wind power framework is basically made out of wind turbine, water electrolysis gadget, hydrogen stockpiling gadget, energy component, power matrix, etc. The proportion of wind power into power lattice and hydrogen production is changed by the control framework, and the wind abridgement force can be ingested maximally, the wind power combination issue is assuaged. The abundance electric force of wind power age is utilized to electrolyze water for hydrogen production. The capacity thickness of hydrogen is expanded by pressure hydrogen stockpiling innovation, strong state hydrogen stockpiling innovation, etc. The fundamental construction of the hydrogen production framework is appeared in Figure 1.

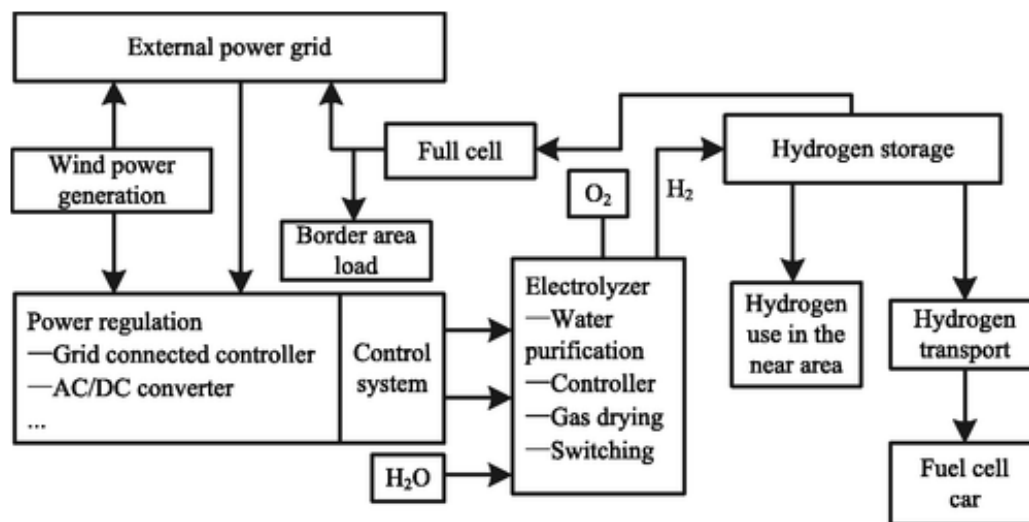

Figure 1. Basic structure of the wind power hydrogen production system.

**3. Main technical attributes of hydrogen production by wind power:**

1 High versatility of wind turbines

Wind turbines not just send electrical energy by a converter gadget to the force network, yet additionally give capacity to the hydrogen electrolytic cell (Takahashi et al., 2008). Subsequently, the high flexibility of the wind turbine is required. That is, the wind turbine should have protection from wind energy variance.

2. High effectiveness, high flexibility, ecological assurance, and security of electrolytic cell

The electrolytic cell of hydrogen production gives high virtue hydrogen by the electrolysis of water, and the interaction needs to guarantee the productivity of energy change. Also, the vacillation of force will have extraordinary effect on the life

and hydrogen virtue of electrolyzer. Accordingly, the interest of the electrolyzer is higher. By improving the anode, impetus, and different materials, the electrolysis cost and hydrogen production effectiveness can be diminished. The presentation can be improved by advancing the disconnection film, and the force variance of the electrolyzer can be improved by changing the interaction boundaries, in order to guarantee the protected activity of the framework (Chang et al., 2016; Nishimura et al., 2017).

3. The adaptability, proficiency, and wellbeing of the wind power hydrogen production control framework

4. Coordinated control arrangement of hydrogen production innovation by wind power incorporates the control arrangement of hydrogen production, hydrogen stockpiling, and energy unit. The principle specialized attributes incorporate the adaptable dissemination of the

proportion of hydrogen production force and safe activity of hydrogen production, hydrogen stockpiling, and hydrogen framework by control framework.

**4. Development prospect of hydrogen production innovation**

The advancement of hydrogen production will prompt the improvement of varying backgrounds, for example, wind power hardware, hydrogen production, hydrogen stockpiling, activity and hydrogen application, and so forth Above all else, during the time spent creating power, countless wind turbines, gearboxes, cutting edges, electric control frameworks, and foundation, for example, pinnacle and bearing are utilized, and related apparatus assembling and engine industry will grow quickly. It will be useful to the exploration of wind turbines and the overhauling of assembling industry. The innovation of hydrogen production by electrolyzing water is solid and proficient, and it has great application prospect. Hydrogen energy use predominantly incorporates hydrogen production, protected and effective capacity, and scale application. It additionally adds to our examination on electrolysis and hydrogen stockpiling innovation, and it advances the improvement of related gear fabricating industry. Hydrogen production innovation will likewise assume a critical part in the advancement of power devices. Energy units have high force age effectiveness and stay away from genuine natural

contamination. As of late, energy unit has accomplished quick turn of events, the important innovations have been progressively full grown, and various sorts of power device transports and little vehicles have effectively led broad exhibit activity.

**5. Off-network wind power age innovation**

The off-matrix electrolysis water framework by wind power consolidates wind power straightforwardly with the new electrolytic water framework. Wind power isn't associated with the framework, which disposes of the effect of wind power on the network, and accomplishes 100% productivity and ease use of wind power. The cycle graph of non-matrix associated hydrogen production is appeared in Figure 2. Wind power created by the wind turbine in the non-matrix associated wind power age can be utilized by basic variety voltage and correction. The voltage is changed from the transformer to the necessary voltage, and the substituting current is amended to coordinate current. In the bigger wind speed variance, the power created by the wind turbine can be utilized. The expense of the hydrogen production framework is under 30% or more than the expense of the matrix associated unit. The off-lattice wind power age innovation is effective to tackle the energy utilization issue, and the hydrogen delivered is spotless, renewable, etc.

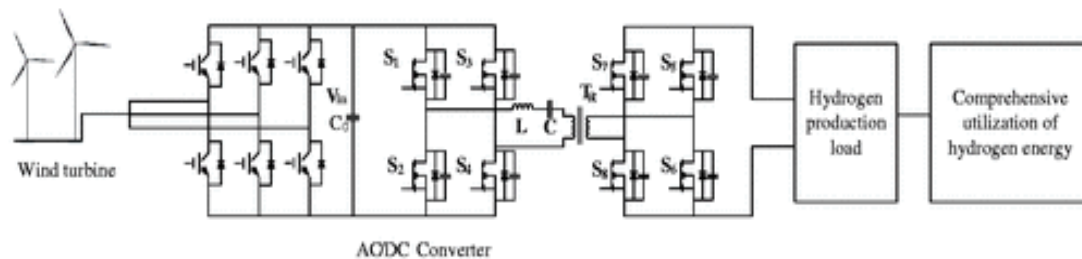

Figure 2. Process diagram of non-grid-connected wind power hydrogen production.

**6. Hydrogen fuel cell motor vehicle**

As one of the main uses of hydrogen energy, the hydrogen fuel cell vehicles have been developed rapidly in recent years. As early as in 1993, Canada Ballard built up the initial zero-outflow energy component transport with a maximum velocity of 72 km/h, fueled by proton trade film. It set off a worldwide innovative work of power module vehicles. Many created nations have contributed a ton of labor and monetary assets to complete examination of electric vehicles controlled by hydrogen power module, and they have gained extraordinary ground. Toyota dispatched the principal hydrogen energy unit vehicle "Mirai" in 2015. At that point, Hyundai additionally dispatched a power device vehicle "Tusheng" (Fu, 2015; Zhang, 2017). In March 2017, Honda dispatched a hydrogen power device vehicle (Clarity) in Japan. At the Frankfurt engine show, Mercedes revealed the main mass-created hydrogen energy component vehicle. China's hydrogen power module vehicles are in the business stage; Foshan (Yunfu) mechanical exchange modern park dispatched hydrogen energy unit vehicle in 2017. The vehicle had entered the limited scale business advancement stage. The world's first hydrogen energy component cable car was done in Tangshan,

Hebei, in 26 October 2017, the contamination free and zero release has been figured it out. The foundation for creating power module vehicles isn't yet finished, and the framework improvement should be additionally reinforced. The traveling mileage and life innovation of the energy component are should have been gotten through. The advancement of the hydrogen production innovation by wind force will incredibly advance the improvement of energy unit vehicles and improve the climate.

**7. New sort of hydrogen production gear**

The quick advancement of the hydrogen production innovation by wind force will prompt the further updating of the hydrogen production hardware by wind power. The high effectiveness electrolytic hydrogen production framework with wide force vacillation will grow quickly, for example, electrolysis framework dependent on soluble electrolysis and electrolytic hydrogen production gear dependent on proton trade layer innovation, energy security, etc. High effectiveness and ease transformation are acknowledged by the redesigning of its materials (Jin, 2017). The issue of low limit of the electrolysis hydrogen production framework likewise should be settled. The

current size of the wind power hydrogen production framework is for the most part inside a couple of megawatts, given that the enormous unified wind power framework has arrived at two or three hundred megawatts or more; the insufficiency of the limit of the electrolysis hydrogen framework will be a significant obstruction to the reasonable use of the joint framework and it is vital to consider the more huge scope and higher limit electrolysis hydrogen production framework. Simultaneously, the innovation of the hydrogen production by wind force will likewise drive the hydrogen energy component to create at a more powerful thickness, and it will drive the hydrogen stockpiling hardware to finish the further overhaul. Also, the innovation will make the hydrogen stockpiling gear have bigger limit and lower cost.

### 8. Future advancement pattern

The 21st century is a time of productive, perfect, safe, and manageable energy use. All nations on the planet have accepted the utilization of energy as the key in the field of logical examination. Lately, wind energy assumes a vital part in the advancement of new energy. The production of hydrogen by the wind power not just gives a lot of hydrogen energy, yet in addition gives and delivers an assortment of items with direct financial advantages. It consolidates develop advances, for example, power age, electrolysis, and hydrogen energy applications. The nonstop development of hydrogen production innovation has continuously supplanted traditional carbon energy, and the transformation productivity can be additionally improved by enormous scope utilization of hydrogen production innovation by wind power. The hydrogen production innovation by wind power is one of the methods of reasonable energy improvement later on. Hydrogen production is of incredible importance to the advancement of future related businesses, for example, wind power industry, keen lattice, power module power age framework, new energy vehicles, etc.

The advancement of hydrogen production by wind force will significantly upgrade the production of hydrogen energy and understand the free utilization of hydrogen in different

fields. The hydrogen energy industry, which depends on power modules, will grow significantly, for example, hydrogen energy component vehicle, disseminated age, crisis power supply, and so on. The utilization of hydrogen energy components for appropriated age can address the issues of various age estimates and give answers for the force supply issues of industry, business, and lodging. In the crisis power supply dependent on hydrogen energy unit, it is applied straightforwardly to data innovation division, bank, medical clinic, and other significant undertakings and organizations. The advancement of hydrogen energy will prompt the spotless usage of fossil energy, which can understand the updating of oil quality and improve item quality for oil refining ventures.

As of now, the wind power hydrogen industry is creating toward the pattern of knowledge and informationization, which will significantly advance the excellent improvement of wind power hydrogen industry. As a sort of clean energy, hydrogen can enormously advance the improvement of worldwide ecological assurance industry and mitigate the issue of an Earth-wide temperature boost.

### 9. Conclusion

In this paper, the improvement of hydrogen production innovation by wind power is profoundly examined and summed up. From one perspective, the hydrogen production innovation can reduce the "wind decrease" issue of wind power age. Then again, hydrogen energy, as a perfect and productive energy, has an extraordinary potential for application as of now. Hydrogen is a significant mechanical gas and uncommon gas, and it is broadly utilized in numerous businesses. In the period of green turn of events, hydrogen energy, as a sort of clean energy, is relied upon to be incredibly evolved. The improvement of hydrogen production is as yet dealing with many key issues, for example, develop wind turbine structure, enhancement of electrolyzer for wind power change, high life energy unit, and enormous limit hydrogen stockpiling hardware.

### References

1. Ali, M, Ekström, J, Alahäivälä, A. (2017) Assessing the upward demand response potential for mitigating the wind generation curtailment: A case study. *European Energy Market* 1: 6.
2. Bartels, JR, Pate, MB, Olson, NK (2010) An economic survey of hydrogen production from conventional and alternative energy sources. *International Journal of Hydrogen Energy* 35(16): 8371–8384.
3. Belmokhtar, K, Doumbia, ML, Agbossou, K (2014) New fuzzy logic based management strategy to improve hydrogen production from hybrid wind power systems. *International Journal of Renewable Energy Research* 4(3): 731–742.
4. Bhandari, R, Trudewind, CA, Zapp, P (2014) Life cycle assessment of hydrogen production via electrolysis – A review. *Journal of Cleaner Production* 85: 151–163.
5. Cai, G, Chen, C, Kong, L (2017) Wind power/hydrogen/fuel cell/supercapacitor hybrid system control strategy. *Transactions of China Electrotechnical Society* 32(17): 84–94.
6. Cao, C, Zhang, B (2017) Fuel cell car. *University Science Popularization* 3: 39–40.
7. Chang, J, Xiao, Y, Luo, Z. (2016) Research progress of non-noble metal catalysts for hydrogen production by water electrolysis. *Journal of Physical Chemistry* 32(7): 1556–1592.
8. Deng, Y (2014) Research on Maximum Wind Energy Capture and Low Voltage Operation of Doubly Fed Wind Generator. PhD Thesis, China: Wuhan University.
9. Duan, W (2015) Wind power consumption has been a worldwide problem in the interpretation of the national energy administration. (Notice on the relevant work of 2015 wind power grid work in 2015). *The Earth* 2015(5): 60–63
10. Dutton, AG, Bleijs, JAM, Dienhart, H. (2000) Experience in the design, sizing, economics, and implementation of autonomous wind-powered hydrogen production systems. *International Journal of Hydrogen Energy* 25(8): 705–722.
11. Fu, T (2015) TOYOTA fuel cell Mirai – The future. *Power Supply Technology* 39(2): 229–230.
12. Fujii, K, Sugiyama, M, Nakamura, S (2015) Hydrogen generation using electrochemical water splitting via electricity generated by nature energy (hydrogen production from renewable energy). *Journal of the Japan Institute of Energy* 94: 27–34.

13. Gao, H (2017) Design and research of medium permanent magnet direct drive synchronous wind generator. *Marine Electricity Technology* 37(6): 23–25.
14. Honnery, D, Moriarty, P (2009) Estimating global hydrogen production from wind. *International Journal of Hydrogen Energy* 34(2): 727–736.
15. Huang, Q (2016) The Scale of Wind Power, the Path and the Thought and Suggestion of the Problem of Abandonment Issues. *Wind Energy Industry* 2016(1): 15–21.
16. Jayasankar, VN, Vinatha, U (2016) Implementation of adaptive fuzzy controller in a grid connected wind-solar hybrid energy system with power quality improvement features. In: *Biennial international conference on power and energy systems: Towards sustainable energy*, Bangalore, India, 21–23 January 2016, pp.1–5. IEEE.
17. Jin, A (2017) More efficient water electrolysis technology. *Petroleum Processing and Petrochemicals* 2: 112–112.