

Distillate Productivity Enhancement by integrating Solar Collectors to Solar still:- A Review

^{*1}Sabhadiya Rajnikant, & ²Kikani Maulik

^{*1}UG Student, department of Mechanical engineering, Vidhyadeep Institute of Technology, Surat, Gujarat, India

²PG Student, Masters in Advanced Materials Analysis, TU Bergakademie Freiberg, Freiberg, Sachsen, Germany

ARTICLE DETAILS

Article History

Published Online: 15 September 2020

Keywords

Solar still, Solar collector, Distillate.

*Corresponding Author

Email: [kikanimaulik2536\[at\]gmail.com](mailto:kikanimaulik2536[at]gmail.com)

ABSTRACT

Water is one of the precious Resources for the survival of living organisms on the earth. As earth having only a small amount of water resources for drinking purpose people in rural and urban areas are getting affected by consuming contaminated water that leads to water-borne diseases. Even ground water has to be properly treated before its use for internal consumption. Salt water contains dissolved and undissolved contents and hence it is not suitable for domestic purpose (cleaning, washing, bathing, etc.). This paper completely deals with the detailed review of a solar still integrated to solar collectors for augmenting the yield of fresh water.

1. Introduction

Due to fast population growth and industrial developments the requirement of quantum of drinking water increased. So far, the more possible way of getting drinking water is from rivers, lakes, wells, etc., which must be purified because they may contain harmful microorganisms and mineral contents. And the purification process involves namely sand filtration, chlorination and boiling. India is approximately having 18% of total world population and only 4% of water source is available for serving the Indian community. However due to the increase in population urbanization and industrial needs the demand for water is drastically increasing. The decrease in annual per capita of water available is from 6042 m³ during 1947–1545 m³ in 2011, whereas, during 2001 the total annual per capita of water available is only 1816 m³. From the latest survey, this water availability will be decreased to 1340 m³ by 2025 and 1140 m³ by the end of 2050. Moreover, the utilization of ground water source is 431 billion cubic meter as an important source for drinking and domestic purpose and nearly 690 billion cubic meter of surface water as a major source for irrigation purpose.

Apart from domestic and industrial sector, the next major user of water is the agricultural sector [2]. There are different techniques available for getting fresh water. Major techniques include thermal and membrane process. As the name implies, thermal desalination process requires heat to convert the saline water into steam, and the steam or vapor is condensed to get fresh water. Fossil fuels are used in the thermal process, and this makes the system uneconomical. Solar desalination is subdivided into two major categories, direct and indirect desalination [1].

Direct desalination system collects the solar energy and converts the saline water into distillate directly, whereas, in indirect desalination system, energy will be collected by solar thermal collectors integrated to a solar still. Desalination through the membrane is a process of getting fresh water from waste or salt water into useful one and using electrical energy. Fouling effect and salt deposition on the membrane surface

makes the maintenance of the process complicated. Almost it consumes 20% of electrical energy for the conversion of salt water to drinking water by pumping water into the perforated membrane. The evolution of using renewable energy has been identified during the 19th century and thus a basin type solar still were designed and fabricated to get fresh water from saline water using solar energy. Solar desalination appears to be the easiest and economical method of producing potable water.

Basin type solar still is the most common and conventional method of getting fresh water utilizing solar energy. Saline water was fed into the basin, and an inclined glass cover is placed over the basin. Solar radiation heats up the water inside the basin to make it evaporate from the top layer. The evaporated vapor inside the still rejects its latent heat through the cover for condensation to attain thermal equilibrium with surroundings. Since the cover is inclined, the condensed water making a droplet on the cover, the droplets slide through it to the distillate collector due to the smooth cover surface.

Many researches are carried out to increase the performance of single basin solar still in the 20th century (Fig. 1). During the 21st century, many authors identified the change in geometry of the basin. Various integrations are made on the solar still for economical viability [9-11]. There are several factors identified from the basin type solar still and discussed in brief by several researchers. The efficiency of the solar still depends upon the following important parameters: -

- Depth of water
- Feed water flow rate
- Cover plate temperature
- Orientation of solar still
- Convective heat transfer from cover plate and side walls
- Design of structures and shapes
- Solar tracking
- Coating
- External enhancement like heat pipe, coolers.

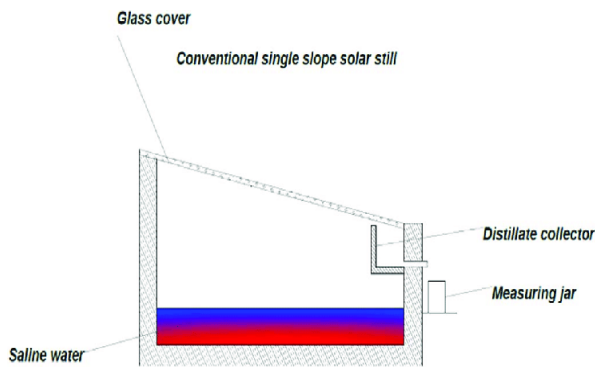

Figure 1. Schematic diagram of a conventional single slope solar still

Many reviews were made on solar still such as geometrical variations [3], inclined solar still [4], factors which affects the solar still performance [6] and condensation [5] on passive solar still. This paper reviews the different enhancement methodology that is used for enhancing the yield of fresh water from the active solar still. From the review, it was identified that the efficiency of solar still with collector-based system depends on the flow rate of water inside the tube surface of the collector, minimum heat loss with outside atmosphere, type of tube and absorber material, and convective heat transfer coefficient between water-Tube basin water. Furthermore, a detailed economic analysis was carried out to analyze the payback period of the collector-based system. The following sections discuss the various methods used by previous researchers for augmenting the yield and possible conclusions are arrived.

2. Enhancement Methodology

2.1. Flat plate collectors

By integrating flat plate collectors to the solar still unit, they found there was a significant increase in the temperature of the brine solution for the better improvement in the yield and efficiency. Fig. 2 show the schematic diagram of a single slope solar still coupled to a flat plate collector. As per Rai et al. [12] the increase in temperature of brine solution depends on parameters such as mass flow, solar intensity, absorber material. Experimental results showed that, two different materials (Jute cloth and dyed jute cloth knitted with wool) in a thermos syphon mode was improved the yield by 48.15% than the simple one for minimum water mass of 20 kg. Further increase in the water mass has decreased the yield and temperature of water in the basin as it was not evenly distributed. The average distillate increases with an increase in water mass up to 6 kg and thereafter decreases. Also, it was reported that the yield depends on mass flow in FPC, and it was observed that there was an improvement in yield when the flow rate was increased from 1 to 3 kg/min. It was recommended to cool glass cover as it was improved the condensation rate.

The effect of coupling a flat plate collector to a solar still for improving the yield of fresh water was experimentally investigated by Badran et al. [13–15]. Experimental investigations were carried out, and parameters like water depth, orientation and solar radiation are the important parameter for enhancing the yield. It was found that coupling flat plate collector increased the yield by 36% (3.5 kg/day of distilled

water) while the yield of conventional still was found as 2.24 kg/day.

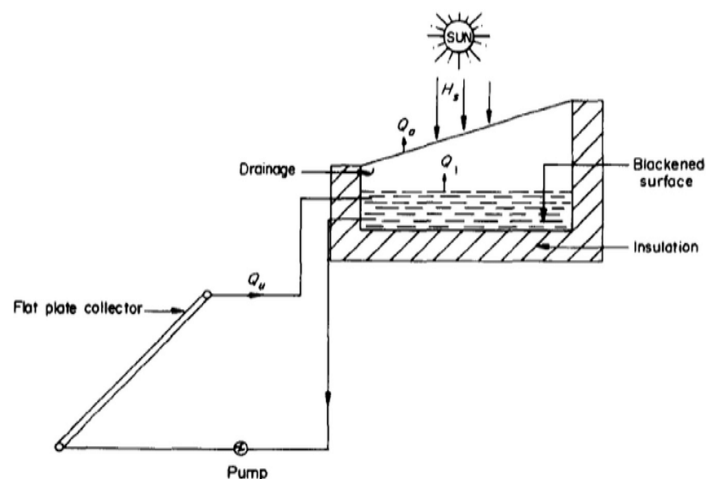

Figure 2. Single slope solar still coupled to flat plate collector [12]

2.2 Tubular Solar collector

The schematic diagram of the single slope solar still integrated with tubular solar collector is shown in Figure 3. The tubular solar collector and solar still receives the solar intensity where the water is heated and evaporated respectively. The inlet fed water is heated using tubular collector and the brine enters into the solar still for evaporation. The transient analytical expression for a single slope solar still with tubular collector was derived by Yadav and Yadav [16]. In the other terms of the solar still explicit equations for water temperature, instantaneous distillate output.

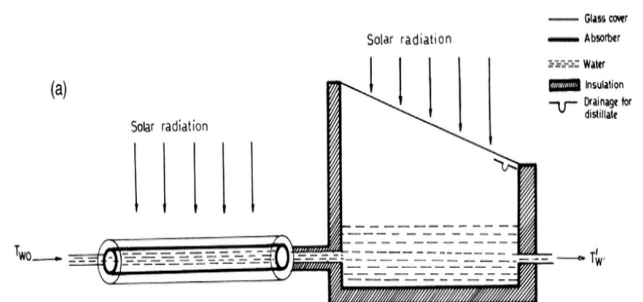

Figure 3. Single slope solar still integrated with tubular solar collector [16]

2.3 Pulsating Heat Pipes

Abad et al. [17] integrated a solar still with pulsating heat pipe Figure 4. The principle of working was same as a refrigerator with a condenser and evaporator. The condenser was fixed in the basin, and an evaporator was fixed on an aluminium sheet and kept inclined with a cover exposed to direct solar radiation. The PHP was made of copper material 2 mm in diameter and has 24 serpentine turns. The tubes were partially filled with water, and direct solar radiation evaporates the water in the tubes and thus was raised the water temperature in the basin by heat transfer. The saline water inside the basin was evaporated and gets condensed by rejecting its latent heat to the surroundings. The yield of fresh water thus depends on parameters such as filling ratio (F_w/F_v) in PHP, solar intensity and depth of water. The results showed

that the yield of fresh water was high and found as 0.80 kg/m²/h with Fw/Fv=40%, whereas the yield drops by 20%, 10%, 12% for Fw/Fv with 30%, 50% and 60% respectively. Also, the solar still yield depended on depth of water and inclination of collector. Heat from the tubes was quickly transferred to the water for evaporation. For the latitude of Tehran, Iran, on 35° inclination of PHP collectors, the yield was maximized to 0.87 kg/m²/h.

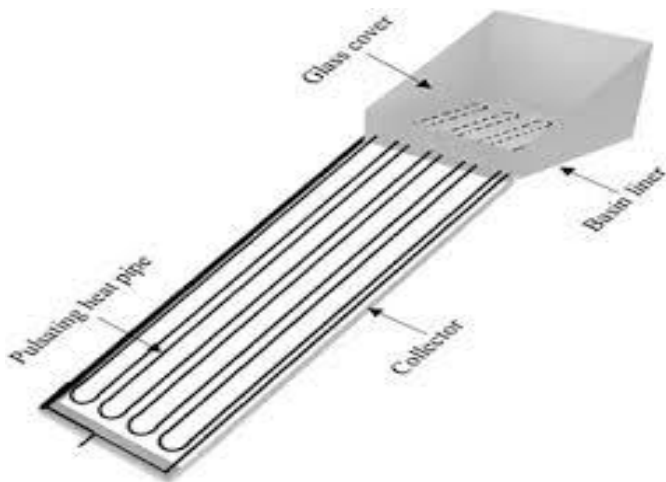

Figure 4. Schematic diagram of Pulsating Heat Pipe with solar still

Concluded that there was increased in yield of 22%, when the solar still was coupled to a concentrator.

The schematic diagram of concentrator coupled single double slope Solar still is shown in figure sand figure 6 respectively. Singh et al. analytically analyzed the effect of water temperature on various Climatic parameters and found out the instanton's efficiency as [19]

2.4 Parabolic Trough

Under Concentrator Parabolic Collector (CPC) in thermo syphon mode two configurations are possible namely, (i) natural (T= f (H)) and (ii) forced circulation mode (T=f (m, u, ρ)). For a natural mode the operational function determined by the height difference of solar still and collectors and for a forced mode the operational function determined by the mass flow.

Due to larger heat from the vapor, the glass temperature relatively increases, and this increase in the temperature decreases the temperature difference. The system is also known to be a regenerative system, where the heat from the glass surface is removed by the wind, flowing water over the surface, artificially flowing air over the surface.

Zaki et al. [18] experimentally investigated a solar still coupled to a concentrator in a natural thermo syphon mode.

With an average solar intensity of 500 W/m² and water depth in the solar still was varied from 5 to 7 cm.

$$\eta = \left[\frac{h_{e,w-g} * h_1}{h_1 + h_2} \right] \left[\frac{T_{wo} - T_g}{I(t)} \right]$$

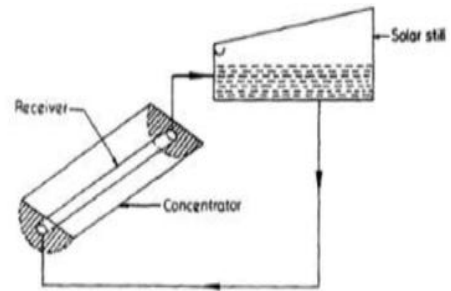

Figure 5. Schematic diagram single basin solar still with parabolic trough collector [19]

2.5 Concentrating Collectors

Tiwari and Suneja [21] made modifications in single slope solar still by reflecting the incoming solar radiation to the basin in an inverted absorber solar still. The system appears to be costly and required tracking mechanisms to reflect the radiation to the bottom absorber. Concentrating receiver reflecting the solar radiation to the bottom hemispherical absorber was first described by Arunkumar et al. [22] (Figure 7). PCM balls were kept in the basin of solar still to study the effect of energy release during the off-shine period. The performance of the still with concentrator has increased the water temperature. During the sunshine hours, PCM in copper balls melts and energy will be stored in the form of liquid. The same heat was utilized by the water during off shine period while convection takes place between higher temperature PCM balls and water. The volume fraction of PCM in copper balls has played a significant role.

The solar still with PCM and concentrator coupled to a hemispherical absorber increase the water temperature by 4 °C up to 94 °C. It was observed that the saturated vapor temperature in the solar still is higher than inner cover temperature and equal to the solar still with and without PCM.

Due to the thermal conductivity of black painted copper balls, the heat stored was quickly released to the water by maintaining the thermal equilibrium. And it was not only due to PCM balls, due to the single point hemispherical absorber focusing the solar radiation for increasing the temperature of water. The percentage increase in yield with PCM was 21.07% higher than without PCM.

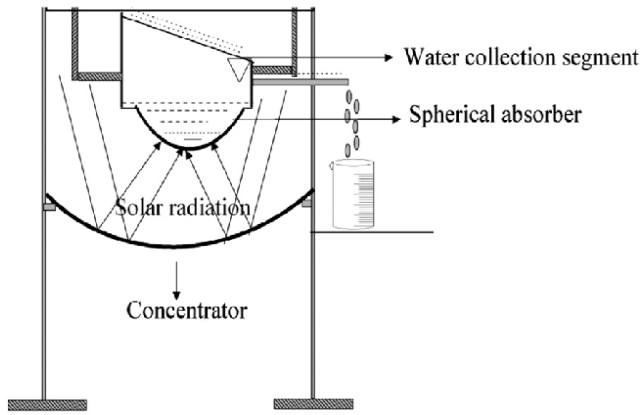

Figure 6. Schematic diagram of hemispherical absorber concentrator assisted solar still [22]

2.6 Single Slope Solar still integrated to Concentric tubular solar still

Arunkumar et al. [23] integrated single slope solar still with concentric tubular solar still (Figure 8) and studied the effect of different flow rate of water over the cover of concentric tubular solar still. The principle mechanism and inner photographic view is shown in Figure 7 and Figure 9 respectively. The results showed that effective cover cooling increases the yield from tubular solar still. The extracted heat from the cover of concentric tube was utilized in the single basin solar still and the efficiency was improved by 75% as compared to solar still without integration.

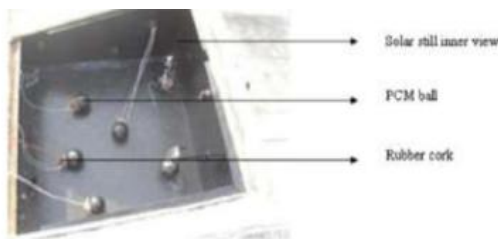

Figure 7. Single slope solar still with phase change material (inside view) [23]

2.7 Concentric tubular solar still integrated to pyramidal solar still

Arunkumar et al. [24] experimentally investigated a pyramidal solar still integrated to a concentric tubular solar still (Figure 11). It is clearly seen that the effect of integrating solar still improves the yield of fresh water from both solar still. A constant gravity feed method was used to cool the cover of tubular solar still and the extracted heat by the water is sent to the basin of pyramidal solar still. The heat extracted from the solar still (Tubular) was utilized for evaporating water from the single basin pyramidal solar still. Experimental results also showed that the flow rate of water for cooling the external cover of the tubular solar still is limited from 10 to 100 ml/min as the extraction of heat from the cover was minimum at increased.

mass flow rate. A similar study with integration of solar still with another solar still, Arunkumar et al. [24] experimentally analyzed using addition of PCM balls inside the basin with the

use of PCM balls inside the basin improved the efficiency and yield of solar still with integration during the off-shine hours

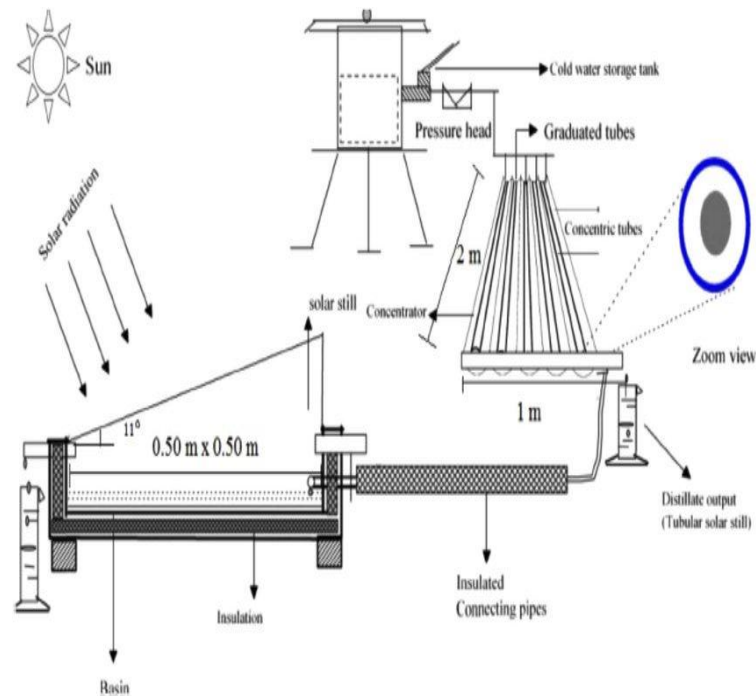

Figure 8. Schematic view of CPC-CTSS coupled with single slope solar still

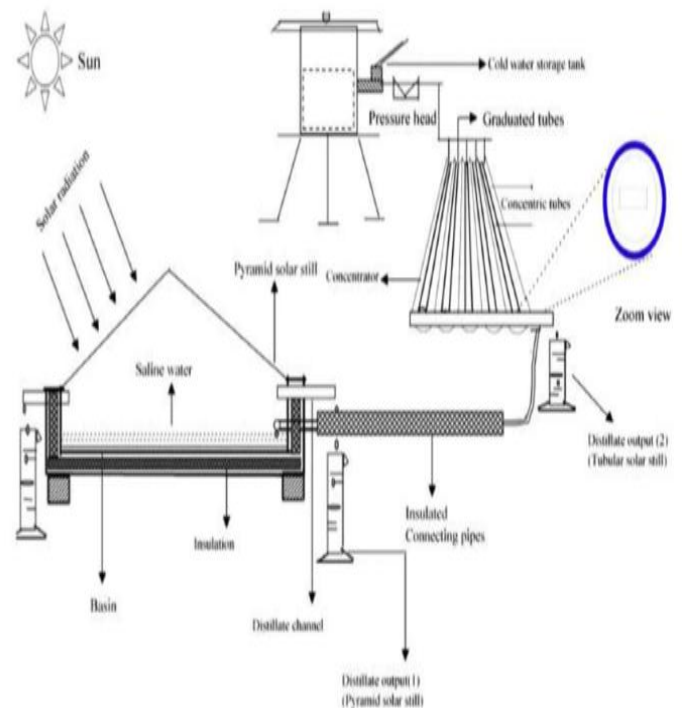

Figure 9. Schematic view CPC-CTSS with pyramid solar still [24]

The evaporative heat transfer coefficient from the solar still with and without PCM balls increased by 7 and 1.76 times respectively. With continuous heat extraction from the tubular solar still and PCM balls the daily yield was found as 3.5 L/m². Whereas, the daily yield from solar still without PCM balls was found as 2.7 L/m². The results show that with continuous heat extraction from the cover of tubular solar still, the total yield from the solar still was approximately found as 7.7 kg/day.

Similarly, when the tubular solar still integrated to a conventional solar still the total yield from both the solar still would be 6.4 kg/day (Figure 12). The process integration with different systems cost was found slightly higher but the overall efficiency and the produced distilled water yield was found augmented.

Table-1 Comparison of yield, percentage improvement and inference from the stud

Sr no.	Innovation in solar still	Ref. no.	Average yield	Improvement in yield
1.	Flate plste collector	[12]	3	53.33
		[13-15]	3.5	36
2	Tubular solar collector	[16]	4.5	-
3	Pulsating Heat pipes	[17]	2.87	7.67
4	Parabolic Trough Collector	[18-20]	5.6	-
5	Single slope solar still integrated to concentric tubular solar still	[23]		
6	Concentrating Collectors	[21-22]	4.4	20.45
7	Concentric tubular solar still integrated to pyramidal solar still	[24]		

3. Conclusion

Table 1 summarizes the yield, percentage increase in fresh water from various active solar still models. From the above discussions on detailed review of solar still integration for augmenting the yield off rash water following conclusions are arrived: -

1. The yield of active solar still depends on the number of passes by the tubes made, mass flow rate of water for effective heat transfer, water depth, solar intensity, forced or natural circulation, inclination of collector, wind velocity, material of tube used for heat exchanger ,glass cover material, insulation thickness and heat loss factor by collector.
2. From the previous studies, it is identified that the glass cover inclination must be equal to the latitude of location as it will receive more solar radiation throughout the inclined plate.
3. For better heat transfer, the use of nano fluids in flat plate collector sand concentrating parabolic trough collector integrated to a serpent tine tube heat exchanger would be better than using saline water.
4. The black rubber can be added to the basin for increasing the absorption rate. Also, the use of synthetic rubber is identified fore placement of absorber material.
5. The use of concentrating collectors improved the efficiency by 137%with PCM balls and with cover cooling technique.
6. Parabolic collectors are more efficient on freshwater yield by using tracking mechanism. For a fixed type concentrating collectors with hemispherical absorber is more efficient. Also, without tracking solar still with internal and external reflectors appeared to be the best technique in improving the yield at low cost as compared to the other expensive techniques.
7. The integration of solar stills with solar collectors increases the yield of fresh water by 36%.

References

- [1] —Progress on Sanitation and Drinking Waterll Update and MDG assessment. UNICEF-WHO; 2015. p. 1–90.
- [2] Satyarthi R, Harris Samuel DG, Nagarajan PK, El-Agouz SA—Review of different solar still for augmenting fresh water yield.ll , J Environ SciTechnol2015, 8(6):244–65.
- [3] Durkaieswaran P, Kalidasa Murugavel K. —Various special designs of single basin passive solar still – A review. ll Renew Sustain Energy Rev 2015, 49:1048–60.
- [4] Kumar Kaviti Ajay, Yadav Akhilesh, Shukla Amit. —Inclined solar still designs: areviewll, Renew Sustain Energy Rev 2016,54:429–51.
- [5] Manokar Muthu, Muruga velKalidasa, Esakkimuthu,—Different parameters affectingthe rate of evaporation and condensation on passive solar still – A reviewll, RenewSustain Energy Rev 2014, 38:309–22.
- [6] Muftah Ali F, Alghoul MA, Fudholi Ahmad, Abdul-Majeed MM, Sopian K, —Factors affecting basin type solar still productivity: a detailed review. ll Renew Sustain Energy Rev 2014, 32:430–47.
- [7] Kabeel AE, Omara ZM, Younes MM. —Techniques used to improve the performance of the stepped solar still—A review. ll Renew Sustain Energy Rev 2015, 46:178–88.
- [8] Harris Samuel DG, Nagarajan PK, Arunkumar T, Kannan E, SathyamurthyRavishankar,—Enhancing the solar still yield by Increasing the surface area of water—A review.ll, Environ Prog Sustain Energy 2016,35(3):815–22.
- [9] Sathyamurthy R, Harris Samuel DG, Nagarajan PK, Arunkumar T,—Geometricalvariations in solar stills for improving the fresh water yield—A review .ll. Desalin Water Treat 2016, 57(45):21145–59.
- [10] Sathyamurthy R, Kennady HJ,Nagarajan PK, Ahsan A—Factors affecting the performance of triangular pyramid solar still.ll, Desalination 2014,344:383–90.
- [11] Nagarajan PK, Vijayakumar D, Paulson V, Chitharthan RK, NarashimuluYoga,SathyamurthyRavishankar. —Performance evaluation of triangular pyramid solarstill for enhancing productivity of fresh water.ll Res J Pharm BiolChemSci2014,5(2):764–71.
- [12] Rai SN, Tiwari GN. —Single basin solar still coupled with flat plate collector.ll, Energy Convers Manag 1983,23(3):145–9.
- [13] Badran OO, Abu-Khader MM. —Evaluating thermal performance of a single slopesolar still.ll, Heat Mass Transf 2007,43(10):985–95.
- [14] Badran OO. —Experimental study of the enhancement parameters on a single slopesolar still productivity.ll Desalination 2007, 209(1):136–43.
- [15] Badran OO, Al-Tahaineh HA. —The effect of coupling a flat-plate collector on the solar still productivity.ll, Desalination 2005, 183(1):137–42.

- [16] Yadav YP, Yadav BP. —Transient analytical solution of a solar still integrated with atubular solar energy collector. *Energy Convers Manag* 1998,39(9):927–30.
- [17] Abad , Kargar Sharif H, Ghiasi M, Jahangiri Mamouri S, Shafii MB. —A novelintegrated solar desalination system with a pulsating heat pipe. *Desalination* 2013,311:206–10.
- [18] Zaki GM, Al-Turki A, Al-Fatani M. —Experimental investigation on concentrator assisted solar-stills. *International J Sol Energy* 1992,11(3–4):193–9.
- [19] Singh SK, Bhatnagar VP, Tiwari GN. —Design parameters for concentrator assisted solar distillation system. *Energy Convers Manag* 1996,37(2):247–52.
- [20] Sinha S, Tiwari GN. —Thermal evaluation of concentrator-assisted solar distillation system. *Heat Recovery System CHP* 1992,12(6):481–8.
- [21] Tiwari GN, Suneja S. —Performance evaluation of an inverted absorber solar still. *Energy Convers Manag* 1998,3(39):173– 80.
- [22] ArunkumarThirugnanasambantham, Denkenberger D, Ahsan Amimul, Jayaprakash R. —The augmentation of distillate yield by using concentrator coupled solar still with phase change material. *Desalination* 2013, 314:189–92.
- [23] Arunkumar T, Velraj R, Denkenberger D, Sathyamurthy R, Vinothkumar K, Porkumaran K, Ahsan A. —Effect of heat removal on tubular solar desalting system. *Desalination* 2016;379:24–33.
- [24] Arunkumar T, Velraj R, Denkenberger DC, Sathyamurthy R, Kumar KV, Ahsan —A. Productivity enhancements of compound parabolic concentrator tubular solar stills. *Renew Energy* 2016,88:391–400