

# Speech Based Information Retrieval System For Farmers

<sup>1</sup>T R Arunkumar & <sup>2</sup>Rajashri Kulkarni

<sup>1</sup>Assistant Professor, Department of Computer Science, Rani Channamma University, Brelagavi-591156(India)

<sup>2</sup>Project Scholar, Department of Computer Science, Rani Channamma University, Brelagavi-591156(India)

---

## ARTICLE DETAILS

### Article History

Published Online: 15 April 2019

### Keywords

Agriculture, Information Retrieval,  
Natural Language Processing, Speech

### \*Corresponding Author

Email: arun[at]rcub.ac.in

---

## ABSTRACT

Agriculture is the field where penetration of the Information Technology is less compared to other fields in the developing countries. For the uneducated farmers, it is very difficult to obtain the information which he needs to plan his farming activities. The speech based information retrieval system for farmers is a system which is intended to provide all the necessary information to the farmer easily at their finger tips. Speech based information retrieval system for farmers is a chat bot which is virtual conversation assistant which allows the user to interact with bot as good as he interacts with other person. This system uses natural language processing techniques to understand and process the user queries. It generates response in both text and speech mode.

---

## 1. Introduction

Agriculture is the major provider of employment to people in many parts of the world. Many people depend on agriculture for their livelihood. Most countries depend on agriculture for their GDP growth. Agricultural technology is getting improvised due to the penetration of the Information Technology. A large number of softwares are being continuously released, to train the farmers. Most of them provide static information about farming, and they require large number of searching steps to get the accurate information and do not provide an interactive way for querying. The speech based information retrieval system for farmers eliminate the drawbacks of conventional systems by allowing farmers to interact with the system and get necessary information with less number of steps. It is a chat bot, a virtual assistant that accepts the queries in a user friendly manner. The input for the system is accepted both in text and speech mode from the user and the textual query will undergo pre-processing step in order to understand the category of the query to which it belongs to, and provide the corresponding useful response. Use of speech synthesis in this system helps the farmers with learning disabilities and literacy problems to use the system efficiently. It also helps the farmers to plan their future activities by predicting data of agriculture products.

## 2. Literature Review

### Existing System

In Kenya a chat bot was developed for farmers. This system helped farmers to negotiate the prices of crops. But this was not that efficient to get the information regarding agriculture. This system can only provide information regarding market prices and was not providing useful information such as weather forecasting, crop disease management etc... which the farmer is in need of. Also this system works on command line and does not support Graphical User Interface. This makes it very difficult for farmers who may have limited technical knowledge. Farmer's Analytical Assistant is another system developed in Karnataka. This system accepts data such as soil type, rainfall, land area, weather data and predicts the suitable crop which can give more yield, where as the system fails to provide any other information market

information. Some of the known informal systems include Apple's Siri, Amazon's Alexa and Microsoft's Cortana which are for generic purpose.

### Proposed System

A chat bot is a conventional application for interacting with the user. These are empowered by Artificial Intelligence, Machine learning techniques. A chat bot is able to understand natural language and communicate with users in their known language. Earlier chat bots were used in fields of media, retail, travel, and in search engines. But we can also use this booming technology in agriculture which can provide relevant responses to the farming related queries. This virtual interactive system uses Natural Language Processing techniques to understand the user queries in their natural language. The system understands even the grammatically incorrect and poorly defined sentences as input queries.

## 3. Motivation

The need of the hour is to make the farmer self sustainable and technology aware and friendly. Farmers will not search for specific application for their mobile or search within the application for the information one needs, or browse through a set of webpages on search engines. Farmers can simply ask the speech bot which is proposed in this system for information rather than searching and querying.

## 4. Scope of the work

A bot is an artificial intelligent computer program which conducts a conversation via auditory or textual methods. Such programs are often designed to convincingly simulate how a human would behave as a conversational partner. Speech bot will be developed based on server and client application. It will be capable of performing the following housing activates in addition to answering the farmers questions:

- New users can register and will be able to use the services.
- Registered user will be able to login into the application.
- If user forgot the password, user can apply for forgot password and rest it.

Speech bot provides the following services.

Text to Speech and Speech to Text:

- Text to Speech makes an android device to read the text and convert it to audio out via the speaker.
- The Android application will be implementing in such a way that when the user request a query to the bot by text or audio, the bot will respond back with text or audio.
- The user can also communicate to bot using speech directly rather than text.

Chat UI:

- Chat UI typically allow the user to send messages through a chat box.
- Chat UI is an interface for user to communicate to the bot.

### 5. Methodology

A natural language processing allows communication to happen between user-to-computer and computer-to-computer or machine-to-machine using human natural languages. There are three main processes which are involved in natural language processing i.e. parsing, semantic interpretation, and knowledge-based structures. The parsing is an analysis of sentence syntax structures. In this step, identification of main linguistic relations is done to parse into subject, predicate, and object of the sentences. The semantic interpretation step yields meaning representation of the texts. The semantic interpretation uses knowledge of word meaning and linguistic structure such as noun or verb transitivity. Actually, processing focus in NLP is a sentence. A sentence could be meant as biggest syntaxes consist of two or more words. A structural relationship between inter-word and inter-sentence is a different. Between both sentence and word, there are two media syntax units i.e. clause and phrase. A word can be functioned as subject, predicate, object, complement, and adverb. A RASA is the leading open source machine learning toolkit used for natural language processing tool. In RASA each dialogue state is saved in a tracker object. There is a tracker object per conversation session, and this is the only state full component in the system. A tracker stores slots, as well as a log of all the events that led to that state and have occurred within a conversation.

The state of a conversation can be reconstructed by replaying all of the events. Rasa takes a set of steps as described in figure below. Step1 is performed by Rasa NLU and all other subsequent steps are handled by Rasa Core.

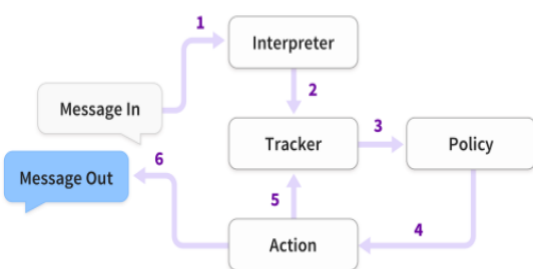

Fig. 1 Architecture on which the proposed system is based.

Algorithm of the proposed system

- Step 1. A message from user is passed to an interpreter which can be Rasa NLU in order to extract the intent, entities, and any other structure and information.
- Step 2. The Tracker is expected to maintain the current state of the conversation. It receives a notification when new message has been received.
- Step 3. The policy module receives the current state of the tracker.
- Step 4. The policy makes a decision to chooses which action needs to be triggered.
- Step 5. The chosen action is logged by the tracker.
- Step 6. The chosen actions are executed which may include providing a feedback to the user.
- Step 7. If the predicted action is not in the 'listen' state then, go back to step 3.

### 6. Process Description

speech bot for farmers is a chat bot which is a computer program that is designed to emulate human and a software interaction in a helpful and constructive manner. The end goal is for the chat bot to provide information from its database that solves specific problems for the user.

The chatbot is consisting of following components

- Chatbot
- Rasa NLU
- Rasa Core
- Knowledge Base

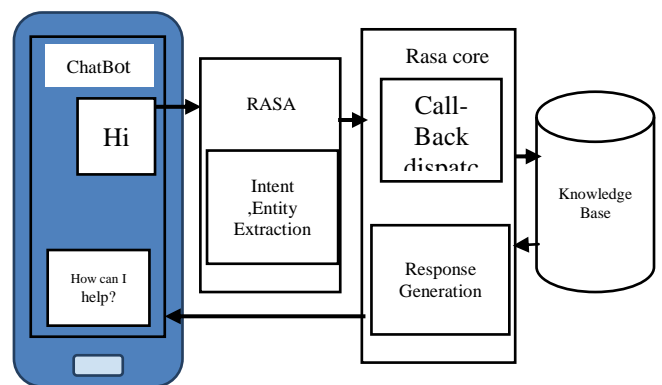

Fig. 2 Process diagram for the proposed system.

The process diagram for the proposed system depicts working process of chat bot. When user types his query and sends it, the text is given to Rasa NLU. The Rasa NLU extracts intent and entities from the user query. Depending on the intent, the Engine Calls the call-Back function and passes entities to it. In the call back function the user query is processed with the help of knowledge base. Then the response is generated and sent to the user interface.

### 7. Conclusion

The system helps farmers to query about the agriculture and get the response in text as well as speech format and also helps in predicting the future data, so that they can plan their activities. The future enhancement can be done by giving the response in their regional languages and prediction can be extended to rainfall, productivity.

**References**

1. Mrs. L. Kannagi ,Ramya .C, Shreya .R, Sowmiya.R "Virtual conversational assistant: The FARMBOT"- International Journal of ..., 2018 - ijetsr.com
2. B Setiaji, FW Wibowo –"Chatbot using a knowledge in database: human-to-machine conversation modeling"-2016 7th International Conference on ..., 2016 - ieexplore.ieee.org
3. T Bocklisch, J Faulkner, N Pawlowski... - arXiv preprint arXiv ..., "Rasa: Open source language understanding and dialogue management" 2017 - arxiv.org
4. A Santangelo, A Augello, A Gentile, G Pilato, S Gaglio -"A Chat-Bot based Multimodal Virtual Guide for Cultural Heritage Tours"- PSC, 2006 - researchgate.net