

Basic fundamental study of signal transmission for minimizing AWGN and enhancing the transmission profile

*¹Mekhla Dadhich, ²Aabhas Mathur & ³Dr. Hemant Dhabhai

¹Scholar, M. Tech., Digital Communication, Aravali Institute of Technical Studies, Udaipur (India)

²Head, Electronics & Communication Department, Aravali Institute of Technical Studies, Udaipur (India)

³Director, Aravali Institute of Technical Studies, Udaipur (India)

ARTICLE DETAILS

Article History

Published Online: 10 November 2018

Keywords

AWGN, SNR, Noise, BER, Signal

Corresponding Author

Email: dadhichmekhla[at]gmail.com

ABSTRACT

Additive White Gaussian Noise (AWGN) is common to every communication channels, which is the statistically random radio noise characterized by a wide frequency range with regards to a signal in the communications channel. This assignment describes two aspects of telecommunications engineering: i) the basic understanding of MATLAB, and ii) the effect of Additive white Gaussian Noise (AWGN) on the transmitted data using based-band simulation under different values of signal-to-noise (SNR) ratio with this tool. In my experiment, I use MATLAB tools to generate the noise sequence, the data sequence, the both data and noise sequence and add them together, recover signal from noisy received data and calculate noise power, calculate SNR and BER and then plot them with different SNR values. Finally, I draw a conclusion from my experiment.

1. Introduction

The random nature of noise in time domain will, on occasions, because a transmitted symbol to be distorted such that the receiver interprets it as a different symbol in the modulation scheme alphabet. Under these circumstances, a given average level of AWGN introduces an average number of symbol errors where each symbol error causes one or more bit errors at output of the receiver. The errors may be characterized by a bit error rate (BER) Additive White Gaussian Noise (AWGN).

A basic and generally accepted model for thermal noise in communication channels, is the set of assumptions that the noise is additive, i.e., the received signal equals the transmit

signal plus some noise, where the noise is statistically independent of the signal. the noise is white, i.e, the power spectral density is flat, so the autocorrelation of the noise in time domain is zero for any non-zero time offset. the noise samples have a Gaussian distribution. Mostly it is also assumed that the channel is Linear and Time Invariant. The most basic results further assume that it is also frequency non-selective. Additive White Gaussian Noise (AWGN) is the statistically random radio noise characterized by a wide frequency range with regards to a signal in a communications channel.

2. Additive white Gaussian noise

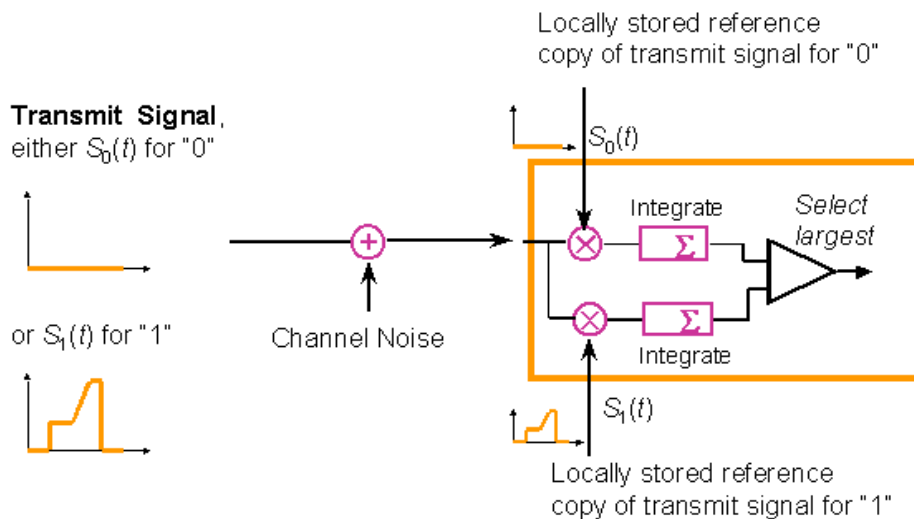

A basic and generally accepted model for thermal noise in communication channels, is the set of assumptions that

- The noise is additive, i.e., the received signal equals the transmit signal plus some noise, where the noise is statistically independent of the signal.

- The noise is white, i.e, the power spectral density is flat, so the autocorrelation of the noise in time domain is zero for any non-zero time offset.
- The noise samples have a Gaussian distribution.

Mostly it is also assumed that the channel is Linear and Time Invariant. The most basic results further assume that it is also frequency non-selective.

3. Optimal signal detection in AWGN LTI channel

The theory for signal transmission over AWGN LTI channels is very well developed and covered in many excellent

text books. Many fundamental theorems in signal detection theory have been developed during World War II, to improve and automate the radar detection of enemy airplanes and ships. The theory of the matched filter receiver is of particular interest. The concept was introduced by D.O. North with the RCA labs in Princeton, in 1943.

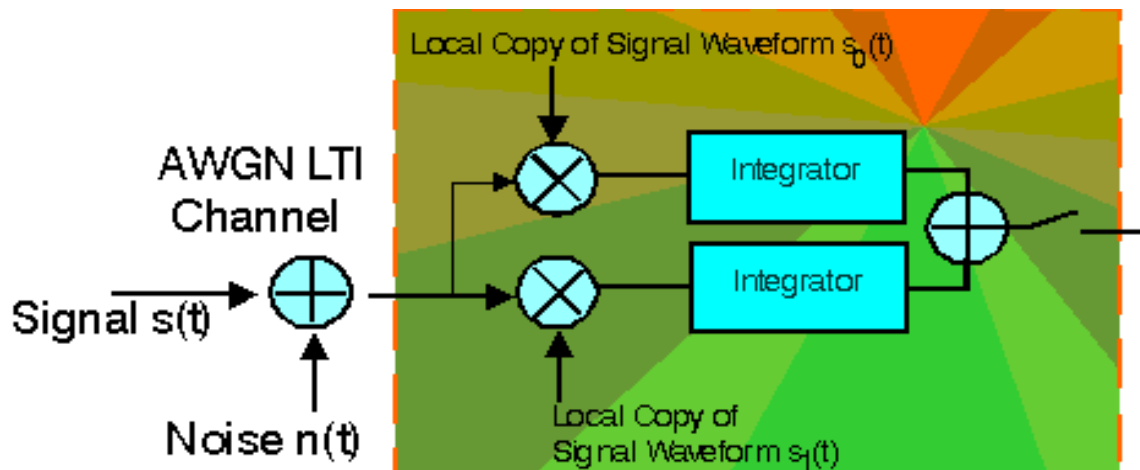

Figure1: possible implementation of a matched filter receiver. The signal is multiplied by a locally stored reference copy and integrated over time (correlation).

The matched filter correlates the incoming signal with a locally stored reference copy of the transmit waveform. The matched filter maximizes the signal-to-noise ratio for a known signal. It can be shown to be the optimal detector if

The channel produces Additive White Gaussian Noise (AWGN),

The channel is linear and time-invariant (LTI), and

An exact time reference is available, the signal amplitude as a function of time is precisely known.

4. Whitened Matched Filter

If the noise is non-white, the matched filter can still be applied. In this case, one can pre-filter the incoming signal, to make the noise component white. This is called a whitening filter. Evidently, this also filters the wanted signal. Therefore, the filtered incoming signal is not "matched to" (i.e., correlated with) the reference transmit signal, but with a reference signal that is fed through the a filter that is identical to the whitening filter. Thus, two copies of the whitening filter are needed. It can be shown that one can build a detector that mathematically is equivalent, but only uses one filter.

Matched Filter for Wireless Channels

If the channel is dispersive, the matched filter concept can still be used, but one must multiply the incoming signal with a locally generated copy of the expected waveform after transmission over the channel. That is, the receiver must estimate the channel impulse response and apply this to the reference signal waveform. The incoming signal is correlated with a reference waveform, which is dispersed in the same manner as the channel disperses the radio signal.

A complication is that such dispersion causes intersymbol interference. Theoretically, it is no longer optimum to detect the received symbols one by one. The "maximum likelihood" (ML) receiver correlates the incoming sequence with dispersed sequences of potentially transmitted waveforms, containing multiple successive bits.

In the special case that the received signal is a direct sequence CDMA signal, this leads to the concept of a rake receiver.

5. AWGN Channel

The AWGN Channel block adds white Gaussian noise to a real or complex input signal. When the input signal is real, this block adds real Gaussian noise and produces a real output signal. When the input signal is complex, this block adds complex Gaussian noise and produces a complex output signal. This block inherits its sample time from the input signal. This block uses the DSP Blockset's Random Source block to generate the noise. The Initial seed parameter in this block initializes the noise generator. Initial seed can be either a scalar or a vector whose length matches the number of channels in the input signal.

6. Conclusion

Thus in this paper we have studied the basic introduction about AWGN. In modern communication systems, band limited AWGN cannot be ignored. When modeling band limited AWGN in the phasor domain, statistical analysis reveals that the amplitudes of the real and imaginary contributions are independent variables which follow the Gaussian distribution model.

References

1. G. Poltyrev, "On coding without restrictions for the AWGN channel," *IEEE Trans. Inf. Theory*, vol. 40, pp. 409–417, Mar. 1994.
2. U. Erez and R. Zamir, "Achieving $1/2 \log(1+\text{SNR})$ on the AWGN channel with lattice encoding and decoding," *IEEE Trans. Inf. Theory*, vol. 50, no. 10, pp. 2293–2314, Oct. 2004.
3. A. Campello, C. Ling, and J. Belfiore, "Algebraic lattice codes achieve the capacity of the compound block-fading channel," *ISIT 2016*. [Online]. Available: <http://arxiv.org/abs/1603.09263>
4. A. Campello, D. Dadush, and C. Ling, "AWGN-goodness is enough: Capacity-achieving lattice codes based on dithered probabilistic shaping," *CoRR*, vol. abs/1707.06688, 2017. [Online]. Available: <http://arxiv.org/abs/1707.06688>
5. Y. Yan, L. Liu, C. Ling, and X. Wu, "Construction of capacity-achieving lattice codes: Polar lattices," Nov. 2014. [Online]. Available: <http://arxiv.org/abs/1411.0187>.
6. N. di Pietro, J. J. Boutros, G. Z'emor, and L. Brunel, "New results on low-density integer lattices," in *Information Theory and Applications (ITA) Workshop*, San Diego, US, Feb. 2013.
7. N. di Pietro, G. Z'emor, and J. J. Boutros, "New results on construction A lattices based on very sparse parity-check matrices," in *IEEE Int. Symp. Inform. Theory (ISIT)*, Istanbul, Turkey, July 2013.